

Clarke®



X-LARGE GARAGE/WORKSHOP

MODEL NO: CIG1432

PART NO: 3503594

ASSEMBLY INSTRUCTIONS

ORIGINAL INSTRUCTIONS

GC0422 - Rev 1

INTRODUCTION

Thank you for purchasing this CLARKE X Large Garage/Workshop.

Before attempting to use this product, please read this manual thoroughly and follow the instructions carefully. In doing so you will ensure the safety of yourself and that of others around you, and you can look forward to your purchase giving you long and satisfactory service.

SPECIFICATIONS

Roof Cover	Polyethylene, UV protected, 305 gsm 1/4" dia braided nylon rope 1" wide X 0.055" thick woven straps (inside end of cover)
Assembled dimensions	30 ft long x 14 ft wide x 12 ft high (9.7 m long x 4.3 m wide x 3.65 m high)
Frame	Round steel tubing, 1-1/2" dia x 0.055" wall thickness
Securing hardware	Steel ratchets (tie down top straps), elastic cord/ball ties
Weight	267 kgs.

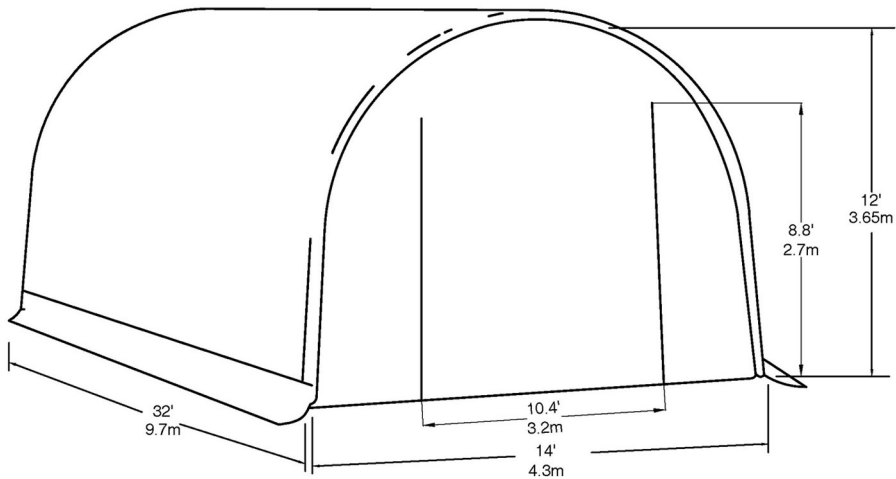

GENERAL SAFETY WARNINGS



WARNING: READ THESE SAFETY INSTRUCTIONS TO REDUCE THE RISK OF INJURY. RETAIN THESE INSTRUCTIONS FOR FUTURE REFERENCE.

DONOT use this product in environments for which it is not intended (i.e. extreme cold, high winds, extreme heat, heavy rainfall, etc).

DO NOT use open flames or cooking or heating devices inside or in close proximity to the garage including all types of stoves, gas heaters, gas lanterns, electric heaters, torches, fly killers, etc. The fabric will burn if left in continuous contact with a naked flame.

DONOT store flammable liquids (petrol, kerosene, propane, etc.) in the garage or operate gas powered vehicles/equipment in or around the garage.

ALWAYS follow the following instructions for mounting the garage.

Due to the height of this garage, an aerial platform or cherry picker will be useful and safer than using ladders. Ensure that any such platforms or ladders are operated on level ground.

We advise that 4 to 6 people may be required to safely erect the frame and install the cover owing to the size and weight.

Select a calm day to install the cover due to the high windage of the cover both during fitting and before it is totally secured in position.

POSITIONING AND INSTALLATION OF THE GARAGE

POSITIONING THE GARAGE

This garage is a temporary structure and is not recommended as a permanent building. It is designed to offer protection from sun, rain, light snow, tree sap and bird droppings etc. It is not designed to shelter equipment from excessively high winds or heavy snow.

Choose your garage location carefully. Check for overhead power lines, tree branches, etc. **DO NOT** install near roofs or other structures that may shed snow, ice or excess ivy run-off onto your garage.

SITING THE GARAGE

Erect your garage on level ground over a firm, level area. Allow enough space near each corner for the tie-down straps supplied to be used as intended. If the ground area is of tarmac or concrete, the use of ground anchor holding-down bolts will be required to anchor the garage to the floor.

Choose a dry location where dampness rising from ground water in the environment will not undermine the protection offered by the garage.

A masonry floor such as block paving or concrete is ideal, but if this is not being supplied, a timber or shuttering plywood floor, protected by a suitable groundsheet should be used. This will help to create a dry storage environment by insulating the garage storage space from ground moisture.

Proper anchoring and keeping the cover tight and free of snow and debris is the responsibility of the user. Damage caused by improper anchoring is not covered under warranty.

CARE OF THE GARAGE STRUCTURE

This garage is **NOT** designed to support heavy snow. Snow or ice accumulation may cause your garage to collapse. To avoid overload, use a ladder to brush snow and ice off the roof top with a broom or mop to prevent collapse with the resultant damage to property or personal injury.

NEVER clear the roof of snow or debris from inside the garage.

DO NOT use hard-edged tools or instruments, such as rakes or shovels to remove snow. These can cause punctures to the cover.

DO NOT use bleach, alkaline or harsh detergents for cleaning. Doing so will damage the material. Soap and warm water are recommended.

In order to reduce risk of burning and avoid damage, **DO NOT**- cook, smoke, refuel or use any open flame devices in or around the garage.

USING THE STORAGE SPACE

NEVER run the engine of any vehicle or machine inside a closed garage. Ensure that there is adequate ventilation for engines or for any work with paints, cleaners. etc. by opening the door panel and keeping it raised.

CONDENSATION

Take steps to avoid the buildup of condensation inside the garage. Cool, damp winter days and moisture from the breath and body heat of personnel may cause condensation on the inside of the top cover of the garage.

A supply of fresh air through the doorway will at least partly remove this issue.

For long term storage of moisture sensitive belongings in all weathers, the use of a Dehumidifier may be required, such as those in the CLARKE range.

A suitable extension lead to a locally available power supply will be required. Condensation will be much less of an issue during the summer months.

If storing a vehicle in your garage over the winter months we recommend the use of a secondary lightweight cover over your vehicle.

COMPONENT PARTS INVENTORY

Part	Description	Dimensions	Qty
1	Top Curved Tube	Ø1.5"x64 ¹ / ₄ "x0.06"	9
2	Short Cuved Tube	Ø1.5"x40"x0.06"	18
3	Long Curved Tube	Ø1.5"x64 ¹ / ₄ "x0.06"	18
4	Straight Tube	Ø1.5"x63 ¹ / ₄ "x0.06"	18
5a	Corner Base Plate (with Tie Down)	6"x5 ³ / ₄ "x4 ¹ / ₄ "	4
5b	Center Base Plate	6"x5 ³ / ₄ "x4 ¹ / ₄ "	14
6	Front Purlin	Ø1.5"x84 ¹ / ₄ "x0.06"	7
7	Swaged Purlin	Ø1.5"x50 ³ / ₄ "x0.06"	49
8	Swaged Brace	Ø1.5"x40"x0.06"	4
9	Brace	Ø1.5"x40"x0.06"	4
10	Short Bolt	M8x2"	22
11	Long Bolt	M8x3 ³ / ₄ "	63
12	Nut	M8	85
13	Ball Tie Down		62
14	Rope	Ø ³ / ₁₆ "x52'	5
15a	Door Panel		1
15b	Back Panel		1
15c	Roof Tarp		1
16	Ratchet Tie Down (part of Corner Base Plate (5a)		4
17	Anchor with steel cable		4

ASSEMBLY



WARNING: DO NOT PLACE THE PRODUCT UNDER TREES FROM WHICH HARD FRUIT SUCH AS APPLES, WALNUTS OR HEAVY PINE CONES, ETC., MAY FALL. KEEP CHILDREN AWAY DURING ASSEMBLY. DO NOT ATTEMPT TO ASSEMBLE THE PRODUCT IF ANY PARTS ARE MISSING. DO NOT LEAVE THE GARAGE UNATTENDED DURING ASSEMBLY IN CASE PERSONAL INJURY OR DAMAGE MAY OCCUR

Have an overview of all parts before attempting construction and make sure all components are supplied. Note: Some parts are listed but are not available individually as replacement parts.

1. Place all parts boxes in the center of the base pad area. Open each parts box labeled "1" through "4" and group each type of part. If parts are not labeled, mark the part number on each item.
2. Remove all packaging materials and place them back in the box. Do not dispose of the packaging materials until assembly is complete.

PREPARATION

1. Select the location for the garage.
2. Make sure that at least six people are available to assemble this product.
3. The foundation should be a concrete slab, concrete footings, pressure treated timbers or railway sleepers. The foundation area or pad area must extend at least 6 inches (15cm) larger than the size of the garage. See examples below.
4. If possible, pick a location for the garage that has a natural or man-made wind break (eg barn, house hedge or hill etc). Level the pad area and clear of any debris.
5. Bring the following tools (not supplied) to the assembly site:
 - Screwdrivers
 - Adjustable wrench
 - Ladder(s)/cherry picker lift or platform

MOUNTING FRAME TUBES, PIPES, AND PURLINS

During this part of the garage assembly, it will progress faster if others help in the process. Also, refer to the Assembly Drawing and Parts List at the start of this manual for guidance.

1. Fit the Straight Vertical Tubes (4) over the Base Plates (5a and 5b) and align the lower mounting holes. See illustration below.

2. Connect the Brace (9) & Swaged Brace (8) together. Attach a Brace (9) and Front Purlin (6) to the first Straight Tube (4) at the Base Plate (5a/b), using long bolt (11) and nut (12).
3. Insert the tapered end of a Swaged Purlin (7) into the end of the Front Purlin (6) and secure using a long bolt (11) and nut (12). Continue assembling purlins in this way to the end of the structure, then attach a Brace (9) between the last Purlin (7) and Straight Tube (4), using a long bolt (11) and nut (12).
4. Repeat steps 1 and 2 at the end of this row.

NOTE: In the entire assembly, all bolts must be mounted from the outside-in, so that the roof cover (15c) will not be damaged by the bolt ends.

5. Assemble and secure three arches at a time. Refer to the illustration following.

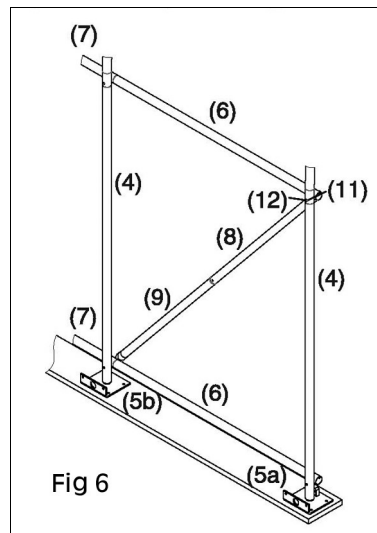

Fig 6

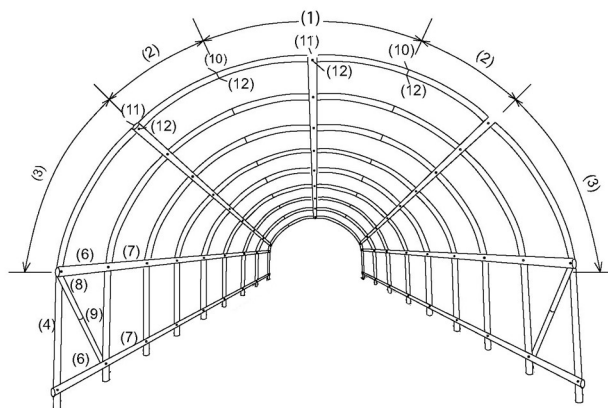

Fig 7

- Lay out three Roof Curved Tubes (1), six Short Curved Tubes (2), and six Long Curved Tubes (3).
- Insert the Short Curved tubes (2) into each end of the Roof Curved tubes (1). Align the screw holes and secure with Short Bolt (10) and Nut (12).
- Insert the Long Curved Tubes (3) into the Short Curved Tubes (2). Align screw holes.

- With the help of two other people, lift the completed arch and insert it into the Straight Vertical Tube (4) on each side. Do the same with the other two arches.
 - Using a ladder to reach the arch, attach Front Purlin (6), then Purlin (7) under the arches using long bolts (11) and nuts (12). Do this in three places each side. Securely tighten.
6. Repeat step 5, assembling the balance of the arches.
 7. When the frame is completed check all nuts and bolts for tightness.

ANCHORING INSTRUCTIONS

IMPORTANT: Due to its size, the garage needs to be anchored down very securely and the frame needs to be tight and secure.

1. From the inside of the garage, place the anchors with Steel Cable (17) on all four corners. Place the remainder of the anchors on the inside of the bows at intervals. See Figure 8.

NOTE: Additional anchors may be required in windy areas.

2. If you are installing on asphalt, drill a deep 1" diameter hole to accept the anchor through the asphalt.
3. If installing in dirt, drive the anchor into the soil using a hammer and the drive rod provided. The more you hammer, the more the anchor goes into the soil, compacting the soil around it. Remove the drive rod once you have established the maximum depth of the anchor.
4. Pull upwards on the cable, rotating the anchor into a locked position. The anchor cuts into the undisturbed soil.
5. After placing all the anchors, wrap the wire cable from each anchor, around the Bottom Rails and securely attach it to itself using clamps (25) (not shown). See Figure 8.

NOTE: If you are in any doubt as to the security of anchoring of your garage you should add more anchors.

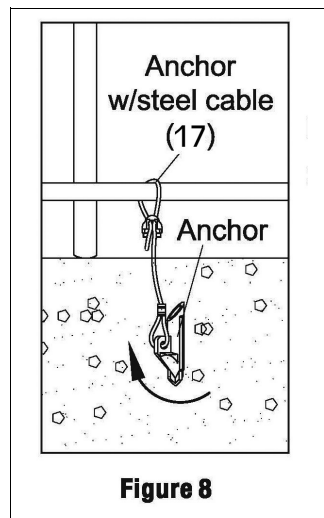

WARNING: ADEQUATE ANCHORING IS ESSENTIAL. IF YOU HAVE ANY DOUBT AS TO THE SECURITY OF THE GARAGE ADD MORE ANCHORS.

COVER PLACEMENT/TIE DOWN

1. Place a protective cover on the ground to one side of the frame.
2. Unfold the roof cover onto the protective cover with the eyelets next to the sill plate. The inside of the cover should be facing up. Do not step on the cover.
3. Weave the rope (14) through each eyelet and around the Front Purlin (6), and the rest of the purlins (7). Refer to the illustration on the top of the next page.

When weaving, leave about 1/2 inch between the Roof Cover and the bottom purlins.

4. After weaving the rope (14), tie down the rope to the end Base Plates.

CAUTION: TAKE CARE NOT TO TEAR THE ROOF COVER EYELETS OUT OF THE FABRIC.

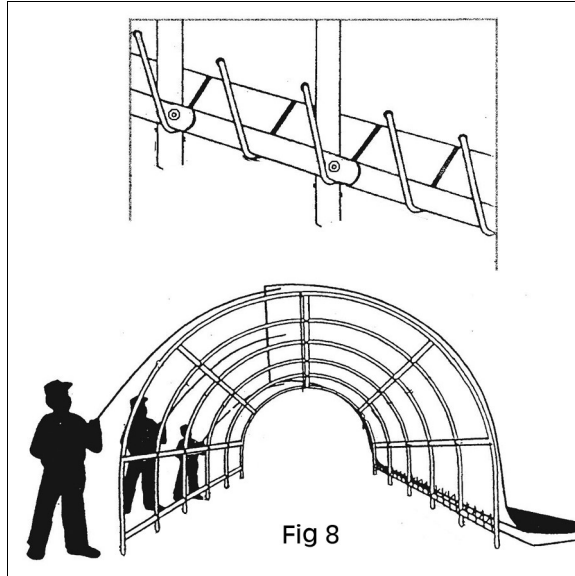

Fig 8

5. Tie the other ropes (14) to the center and end eyelets on the other side of the cover.
6. Throw the ropes over the top of the frame to the other side. See illustration above.
7. With the help of two others, carefully pull the Roof Cover over the frame. Keep the cover centered on the frame while pulling it over. It may help to have others guide the feeding of the cover from where it is lying.

CAUTION: DO NOT TEAR THE ROOF COVER. IF THE ROOF COVER CATCHES ON PART OF THE FRAME, STOP PULLING THE ROPES. GET ON A LADDER AND UNDO THE CATCH. IF IT HAPPENS TO BE A BOLT PLACED UPSIDE DOWN, REVERSE THE BOLT MOUNTING BEFORE PROCEEDING.

8. With the roof cover completely over the frame, weave the rope (14) through each eyelet and around the Front Purlin (6), and the rest of the purlins (7). as shown in the illustration above.

9. After weaving the rope (14), tie down the rope to the end frame.

10. Attach the Split Door Panel (15a) to the front entrance of the garage using Ball Tie Downs (13) through each eyelet.

11. Attach the Solid End Panel (15b) to the back of the garage using Ball Tie Downs (13) through each eyelet.

12. Attach the Ratchet Tie Down (16) to each corner.

13. At each corner of the roof cover is a flat strap. Feed the flat strap through the front (and back) covers, into the Ratchet Tie Down (16) and begin to tighten the each ratchet alternately, a little at a time. When this happens, the 6 inch roof skin flap will fold over the frame ends as shown below-left.

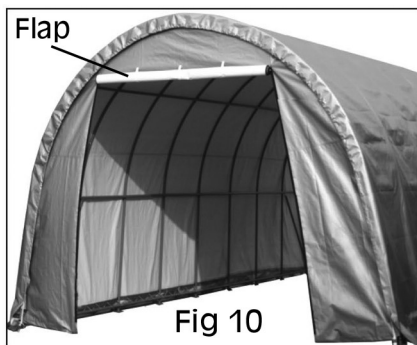
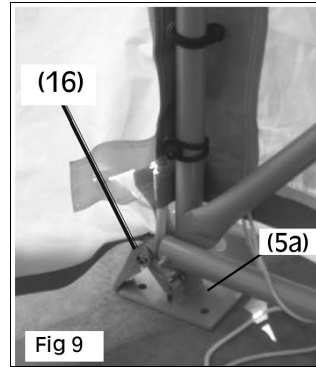

14. Check periodically (two to three times in the first week) and tighten the ratchet tie-downs and all hardware as needed. You may need to remove and re-set the ratchet to allow for more strap material becoming wound around the ratchet spindle.



WARNING: IF POSITIONING THE GARAGE IN A WINDY LOCATION ALWAYS ENSURE THE FRONT DOOR IS KEPT FULLY CLOSED TO PREVENT WIND LIFTING IT FROM INSIDE.

WARNING: SERIOUS INJURY TO PERSONS OR PROPERTY COULD RESULT IF THE GARAGE IS NOT SECURELY ANCHORED.

NOTE: If you are in any doubt as to the security of anchoring of your garage you should add more anchors.

DISASSEMBLY

When disassembling the garage depress the spring-loaded bar to disengage the ratchet and open the ratchet handle completely to allow the webbing strap to pull through.

PLEASE RE-READ ALL WARNINGS ON PAGE 2 OF THESE INSTRUCTIONS.

To dismantle, execute all instructions in reverse order.

Store your garage in a cool, dry location between seasons to prolong the usable life of all components. Components are not equally durable and will require replacement over time at differing intervals.

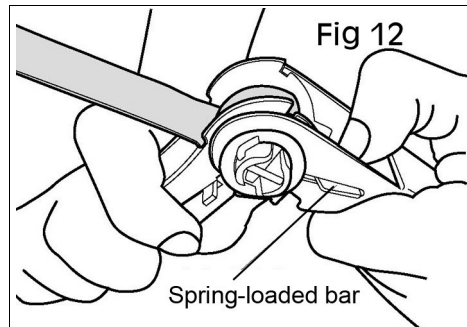

MAINTENANCE

1. The cover can be cleaned with soap and water.
2. For best performance, keep all parts of this product clean and dry.
3. Check periodically (two to three times in the first week) and tighten the turnbuckles and all hardware as needed. You may need to remove and re-set the turnbuckles to allow for more strap material becoming wound around the spindle.
4. To dismantle, execute all instructions in reverse order.
5. Store your garage in a cool, dry location between seasons to prolong the usable life of all components. Components are not equally durable and will require replacement over time at differing intervals.

GUARANTEE

This product is guaranteed against faulty manufacture for a period of 12 months from the date of purchase. Please keep your receipt which will be required as proof of purchase.

This guarantee is invalid if the product is found to have been abused or tampered with in any way, or not used for the purpose for which it was intended.

Faulty goods should be returned to their place of purchase, no product can be returned to us without prior permission. This guarantee does not effect your statutory rights.

A SELECTION FROM THE VAST RANGE OF

Clarke®

QUALITY PRODUCTS



AIR COMPRESSORS
From DIY to industrial, Plus air tools, spray guns and accessories.

GENERATORS
Prime duty or emergency standby for business, home and leisure.

POWER WASHERS
Hot and cold, electric and engine driven - we have what you need

WELDERS
Mig, Arc, Tig and Spot. From DIY to auto/industrial.

METALWORKING
Drills, grinders and saws for DIY and professional use.

WOODWORKING
Saws, sanders, lathes, mortisers and dust extraction.

HYDRAULICS
Cranes, body repair kits, transmission jacks for all types of workshop use.

WATER PUMPS
Submersible, electric and engine driven for DIY, agriculture and industry.

POWER TOOLS
Angle grinders, cordless drill sets, saws and sanders.

STARTERS/CHARGERS
All sizes for car and commercial use.

PARTS & SERVICE: 0208 988 7400

Parts Enquiries
Parts@clarkeinternational.com

Servicing & Technical Enquiries
Service@clarkeinternational.com

SALES: UK 01992 565333 or Export 00 44 (0)1992 565335

Clarke INTERNATIONAL Hemnall Street, Epping, Essex CM16 4LG
www.clarkeinternational.com